



Integral Horsepower DC Motor

Designed for operation with an SCR Control

Any trademarks used in this manual are the property of their respective owners.

Important:

Be sure to check www.baldor.com to download the latest version of this manual in Adobe Acrobat PDF format.

Table of Contents

Section 1	
General Information	1-1
Overview	1-1
Important:	1-1
Safety Notice:	1-1
Receiving	1-2
Handling Handling	1-2
Storage	1-3
Preparation for Storage	1-3
Removal From Storage	1-4
EMC Compliance Statement for European Union	1-4
Section 2	
Installation & Operation	2-1
Overview	2-1
Location	2-1
Mounting	2-1
Alignment	2-1
Doweling & Bolting	2-1
Guarding	2-2
Power Connection	2-2
Conduit Box	2-2
Power	2-2
Motor Connections	2-2
Thermostats	2-3
Blower Ventilation System	2-3
Initial Start-Up	2-4
Coupled Start-Up	2-4
Section 3	
Maintenance & Troubleshooting	3-1
General Inspection	3-1
Relubrication & Bearings	3-1
Type of Grease	3-1
Lubrication Intervals	3-1
Lubrication Procedure	3-2
Brush Replacement	3-3
Brush Springs	3-3
Poor Brush Life	3-3
Brush Chatter or Bounce	3-3
Brush Sparking	3-3
Carbon Brushes For Special Operating Conditions	3-3
Authorized Service	3-3
Humidity and Brush Wear	3-4
Commutator	3-4
Rapid Commutator Wear	3-4
Blowers & Filters	3-4
Guide To Commutator Appearance	3-5
Continued on next page	
Troubleshooting	3-6

Armature Overheating	3-6
Field Coil Overheating	3-6
Excessive Load	3-6
Jogging and Repeated Starts	3-6
Heating	3-6
Thermostat	3-6
Reflash Instructions	3-7
Accessories	3-8
Section 4	
Connection Diagrams	4-1

Section 1

General Information

- Overview** This manual contains general procedures that apply to Baldor Motor products. Be sure to read and understand the Safety Notice statements in this manual. For your protection, do not install, operate or attempt to perform maintenance procedures until you understand the Warning and Caution statements.
A Warning statement indicates a possible unsafe condition that can cause harm to personnel.
A Caution statement indicates a condition that can cause damage to equipment.
- Important:** This instruction manual is not intended to include a comprehensive listing of all details for all procedures required for installation, operation and maintenance. This manual describes general guidelines that apply to most of the motor products shipped by Baldor. If you have a question about a procedure or are uncertain about any detail, Do Not Proceed. Please contact your Baldor District Office for more information or clarification.
Before you install, operate or perform maintenance, become familiar with the following:
- NEMA Publication MG-2, Safety Standard for Construction and guide for Selection, Installation and Use of Electric Motors and Generators.
 - The National Electrical Code
 - Local codes and Practices
- Safety Notice:** This equipment contains high voltage! Electrical shock can cause serious or fatal injury. Only qualified personnel should attempt installation, operation and maintenance of electrical equipment.
Be sure that you are completely familiar with NEMA publication MG-2, safety standards for construction and guide for selection, installation and use of electric motors and generators, the National Electrical Code and local codes and practices. Unsafe installation or use can cause conditions that lead to serious or fatal injury. Only qualified personnel should attempt the installation, operation and maintenance of this equipment.
- WARNING:** Do not touch electrical connections before you first ensure that power has been disconnected. Electrical shock can cause serious or fatal injury. Only qualified personnel should attempt the installation, operation and maintenance of this equipment.
- WARNING:** Disconnect all electrical power from the motor windings and accessory devices before disassembling of the motor. Electrical shock can cause serious or fatal injury.
- WARNING:** Be sure the system is properly grounded before applying power. Do not apply AC power before you ensure that all grounding instructions have been followed. Electrical shock can cause serious or fatal injury.
- WARNING:** Avoid extended exposure to machinery with high noise levels. Be sure to wear ear protective devices to reduce harmful effects to your hearing.
- WARNING:** Surface temperatures of motor enclosures may reach temperatures which can cause discomfort or injury to personnel accidentally coming into contact with hot surfaces. When installing, protection should be provided by the user to protect against accidental contact with hot surfaces. Failure to observe this precaution could result in bodily injury.
- WARNING:** Guards must be installed for rotating parts to prevent accidental contact by personnel. Accidental contact with body parts or clothing can cause serious or fatal injury.
- WARNING:** This equipment may be connected to other machinery that has rotating parts or parts that are driven by this equipment. Improper use can cause serious or fatal injury. Only qualified personnel should attempt to install operate or maintain this equipment.
- WARNING:** Do not by-pass or disable protective devices or safety guards. Safety features are designed to prevent damage to personnel or equipment. These devices can only provide protection if they remain operative.
- WARNING:** Avoid the use of automatic reset devices if the automatic restarting of equipment can be hazardous to personnel or equipment.
- WARNING:** Be sure the load is properly coupled to the motor shaft before applying power. The shaft key must be fully captive by the load device. Improper coupling can cause harm to personnel or equipment if the load decouples from the shaft during operation.
- WARNING:** Use proper care and procedures that are safe during handling, lifting, installing, operating and maintaining operations. Improper methods may cause muscle strain or other harm.
- WARNING:** Pacemaker danger – Magnetic and electromagnetic fields in the vicinity of current carrying carrying conductors and permanent magnet motors can result result in a serious health hazard to persons with cardiac pacemakers, metal implants, and hearing aids. To avoid risk, stay way from the area surrounding a permanent magnet motor.
- WARNING:** Before performing any motor maintenance procedure, be sure that the equipment connected to the motor shaft cannot cause shaft rotation. If the load can cause shaft rotation, disconnect the load from the motor shaft before maintenance is performed. Unexpected mechanical rotation of the motor parts can cause injury or motor damage.
- WARNING:** Motors that are to be used in flammable and/or explosive atmospheres must display the UL label on the nameplate along with CSA listed logo. Specific service conditions for these motors are defined in NFPA 70 (NEC) Article 500.
- WARNING:** Adjustable speed controls may apply hazardous voltages to the motor leads after power to the controller has been turned off. Verify the controller is incapable of delivering hazardous voltages and that the voltage at the motor leads is zero before proceeding. Failure to observe this precaution may result is severe bodily injury or death.
- WARNING:** Use only UL/CSA listed explosion proof motors in the presence of flammable or combustible vapors or dust.
- WARNING:** Motors that are to be used in flammable and/or explosive atmospheres must display the UL label on the nameplate along with CSA listed logo. Specific service conditions for these motors are defined in NFPA 70 (NEC) Article 500.

Safety Notice Continued

- WARNING:** UL Listed motors must only be serviced by UL Approved Authorized Baldor Service Centers if these motors are to be returned to a hazardous and/or explosive atmosphere.
- WARNING:** This equipment is at line voltage when AC power is connected. Disconnect and lockout all ungrounded conductors of the ac power line before proceeding. Failure to observe these precautions could result in severe bodily injury or loss of life.
- WARNING:** Rotating parts can cause serious or fatal injury. If relubrication is performed with the motor running, to avoid injury do not contact any rotating parts.
- WARNING:** Solvents can be toxic and/or flammable. Follow manufacturer's safety procedures and directions.
- WARNING:** Space Heaters operate at line voltage. Disconnect power to space heaters before performing maintenance work on motor. Failure to observe this precaution could result in severe bodily injury or loss of life.
- WARNING:** Thermostat contacts automatically reset when the motor has slightly cooled down. To prevent injury or damage, the control circuit should be designed so that automatic starting of the motor is not possible when the thermostat resets.
- Caution:** To prevent premature equipment failure or damage, only qualified maintenance personnel should perform maintenance.
- Caution:** Do not over-lubricate motor as this may cause premature bearing failure.
- Caution:** Do not lift the motor and its driven load by the motor lifting hardware. The motor lifting hardware is adequate for lifting only the motor. Disconnect the load (gears, pumps, compressors, or other driven equipment) from the motor shaft before lifting the motor.
- Caution:** If eye bolts are used for lifting a motor, be sure they are securely tightened. The lifting direction should not exceed a 20 ° angle from the shank of the eye bolt or lifting lug. Excessive lifting angles can cause damage.
- Caution:** Do not use the coupling to compensate for poor alignment. This can result in vibration, noise, coupling wear, overloaded bearings and early failure.
- Caution:** To prevent equipment damage, be sure that the electrical service is not capable of delivering more than the maximum motor rated amps listed on the rating plate.
- Caution:** If a Motor Insulation test (High Potential Insulation test) must be performed, disconnect the motor from any Speed Control or drive to avoid damage to connected equipment.
- Caution:** Do not use Silicone grease or Sealing Compounds (RTV) on or in the vicinity of the motor or its air supply. Silicone vapor inside the motor will result in extremely rapid brush wear.
- Caution:** Series wound motors must never be allowed to run with no load (broken belt etc.) An unloaded motor may reach destructive high speeds.
- Caution:** Motors designed for forced ventilation must have cooling air when fields are excited at rated voltage. Installations having the air supply interrupted when the motor is not operating must have field disconnected or field voltage reduced to 50% rated by means of field economizing resistor and relay or motor insulation life will be significantly reduced.
- If you have any questions or are uncertain about any statement or procedure, or if you require additional information please contact your Baldor District Office.

Receiving

- Each Baldor Electric Motor is thoroughly tested at the factory and carefully packaged for shipment. When you receive your motor, there are several things you should do immediately. Do not unpack until ready for use.
1. Observe the condition of the shipping container and report any damage immediately to the commercial carrier that delivered your motor.
 2. Verify that the part number of the motor you received is the same as the part number listed on your purchase order.

Lifting Magnet Generators

Treat Baldor lifting magnet generators like motors during installation or maintenance. Generally, they have standard compound self-excited fields. Standard magnetism is for counter-clockwise rotation (facing the drive end of the motor). To reverse (operate clockwise), refer to the connection diagrams in Section 4 of this manual.

- Caution:** Do not lift the motor and its driven load by the motor lifting hardware. The motor lifting hardware is adequate for lifting only the motor. Disconnect the load (gears, pumps, compressors, or other driven equipment) from the motor shaft before lifting the motor.

Handling

- The motor should be lifted using the lifting lugs or eye bolts provided.
1. Use the lugs or eye bolts provided to lift the motor. Never attempt to lift the motor and additional equipment connected to the motor by this method. The lugs or eye bolts provided are designed to lift only the motor. Never lift the motor by the motor shaft or the hood of a WP11 motor. If eye bolts are used for lifting a motor, be sure they are securely tightened. The lifting direction should not exceed a 20° angle from the shank of the eye bolt. Excessive lifting angles can cause motor damage.
 2. To avoid condensation inside the motor, do not unpack until the motor has reached room temperature. (Room temperature is the temperature of the room in which it will be installed). The packing provides insulation from temperature changes during transportation.
 3. When lifting a WP11 (Weather Proof Type 2) motor, do not lift the motor by inserting lifting lugs into holes on top of the cooling hood. These lugs are to be used for hood removal only. A spreader bar should be used to lift the motor by the cast lifting lugs located on the motor frame.

-
- If the motor must be mounted to a plate with the driven equipment such as pump, compressor etc., it may not be possible to lift the motor alone. For this case, the assembly should be lifted by a sling around the mounting base. The entire assembly can be lifted as an assembly for installation. Do not lift the assembly using the motor lugs or eye bolts provided. Lugs or eye bolts are designed to lift motor only. If the load is unbalanced (as with couplings or additional attachments) additional slings or other means must be used to prevent tipping. In any event, the load must be secure before lifting.

Storage

Storage requirements for motors and generators that will not be placed in service for at least six months from date of shipment. To avoid condensation inside the motor, do not unpack until the motor has reached room temperature. (Room temperature is the temperature of the room in which it will be installed). The packing provides insulation from temperature changes during transportation.

Improper motor storage will result in seriously reduced reliability and failure. An electric motor that does not experience regular usage while being exposed to normally humid atmospheric conditions is likely to develop rust or rust particles on surrounding surfaces to contaminate the bearings. The electrical insulation may absorb an excessive amount of moisture leading to the motor winding failure.

A wooden crate "shell" should be constructed to secure the motor during storage. This is similar to an export box but the sides & top must be secured to the wooden base with lag bolts (not nailed as export boxes are) to allow opening and reclosing many times without damage to the "shell".

Minimum resistance of motor winding insulation is 5 Meg ohms or the calculated minimum, which ever is greater.

Minimum resistance is calculated as follows: $R_m = kV + 1$

where: R_m is minimum resistance to ground in Meg-Ohms and
kV is rated nameplate voltage defined as Kilo-Volts.)

Example: For a 480VAC rated motor $R_m = 1.48$ meg-ohms (use 5 M Ω).

For a 4160VAC rated motor $R_m = 5.16$ meg-ohms.

Preparation for Storage

- Some motors have a shipping brace attached to the shaft to prevent damage during transportation. The shipping brace, if provided, must be removed and stored for future use. The brace must be reinstalled to hold the shaft firmly in place against the bearing before the motor is moved.
 - Store in a clean, dry, protected warehouse where control is maintained as follows:
 - Shock or vibration must not exceed 2 mils maximum at 60 hertz, to prevent the bearings from brinelling. If shock or vibration exceeds this limit vibration isolation pads must be used.
 - Storage temperatures of 10°C (50°F) to 49°C (120°F) must be maintained.
 - Relative humidity must not exceed 60%.
 - Motor space heaters (when present) are to be connected and energized whenever there is a possibility that the storage ambient conditions will reach the dew point. Space heaters are optional.
- Note: Remove motor from containers when heaters are energized, reprotect if necessary.
- Measure and record the resistance of the winding insulation (dielectric withstand) every 30 days of storage.
 - If motor insulation resistance decreases below the minimum resistance, contact your Baldor District office.
 - Place new desiccant inside the vapor bag and re-seal by taping it closed.
 - If a zipper-closing type bag is used instead of the heat-sealed type bag, zip the bag closed instead of taping it. Be sure to place new desiccant inside bag after each monthly inspection.
 - Place the shell over the motor and secure with lag bolts.
 - Where motors are mounted to machinery, the mounting must be such that the drains and breathers are fully operable and are at the lowest point of the motor. Vertical motors must be stored in the vertical position. Storage environment must be maintained as stated in step 2.
 - Motors with anti-friction bearings are to be greased at the time of going into extended storage with periodic service as follows:
 - Motors marked "Do Not Lubricate" on the nameplate do not need to be greased before or during storage.
 - Ball and roller bearing (anti-friction) motor shafts are to be rotated manually every 3 months and greased every 6 months in accordance with the Maintenance section of this manual.
 - Sleeve bearing (oil lube) motors are drained of oil prior to shipment. The oil reservoirs must be refilled to the indicated level with the specified lubricant, (see Maintenance). The shaft should be rotated monthly by hand at least 10 to 15 revolutions to distribute oil to bearing surfaces.
 - "Provisions for oil mist lubrication" – These motors are packed with grease. Storage procedures are the same as paragraph 5b.
 - "Oil Mist Lubricated" – These bearings are protected for temporary storage by a corrosion inhibitor. If stored for greater than 3 months or outdoor storage is anticipated, connected to the oil mist system while in storage. If this is not possible, add the amount of grease indicated under "Standard Condition" in Section 3, then rotate the shaft 15 times by hand.
 - All breather drains are to be fully operable while in storage (drain plugs removed). The motors must be stored so that the drain is at the lowest point. All breathers and automatic "T" drains must be operable to allow breathing and draining at points other than through the bearings around the shaft. Vertical motors should be stored in a safe stable vertical position.
 - Coat all external machined surfaces with a rust preventing material.
An acceptable product for this purpose is Exxon Rust Ban # 392.
 - Carbon brushes should be lifted and held in place in the holders, above the commutator, by the brush holder fingers. The commutator should be wrapped with a suitable material such as cardboard paper as a mechanical protection against damage.

Non-Regreaseable Motors

Non-regreasable motors with “Do Not Lubricate” on the nameplate should have the motor shaft rotated 15 times to redistribute the grease within the bearing every 3 months or more often.

All Other Motor Types

Before storage, the following procedure must be performed.

1. Remove the grease drain plug, if supplied, (opposite the grease fitting) on the bottom of each bracket prior to lubricating the motor.
2. The motor with regreasable bearing must be greased as instructed in Section 3 of this manual.
3. Replace the grease drain plug after greasing.
4. The motor shaft must be rotated a minimum of 15 times after greasing.
5. Motor Shafts are to be rotated at least 15 revolutions manually every 3 months and additional grease added every nine months (see Section 3) to each bearing.
6. Bearings are to be greased at the time of removal from storage.

Removal From Storage

1. Remove all packing material.
2. Measure and record the electrical resistance of the winding insulation resistance meter at the time of removal from storage. The insulation resistance must not be less than 50% from the initial reading recorded when the motor was placed into storage. A decrease in resistance indicates moisture in the windings and necessitates electrical or mechanical drying before the motor can be placed into service. If resistance is low, contact your Baldor District office.
3. Regrease the bearings as instructed in Section 3 of this manual.
4. Reinstall the original shipping brace if motor is to be moved. This will hold the shaft firmly against the bearing and prevent damage during movement.

EMC Compliance Statement for European Union

The motors described in this instruction manual are designed to comply 2004/108/EC . These motors are commercial in design and not intended for residential use. When used with converters, please consult converter manufacturers literature regarding recommendations on cable types, cable shielding, cable shielding termination, connection recommendations and any filters which may be recommended for EMC compliance. For additional information, consult Baldor MN1383.

Section 2

General Information

Overview

Installation should conform to the National Electrical Code as well as local codes and practices. When other devices are coupled to the motor shaft, be sure to install protective devices to prevent future accidents. Some protective devices include, coupling, belt guard, chain guard, shaft covers etc. These protect against accidental contact with moving parts. Machinery that is accessible to personnel should provide further protection in the form of guard rails, screening, warning signs etc.

Caution:

Do not use Silicone grease or Sealing Compounds (RTV) on or in the vicinity of the motor or its air supply. Silicone vapor inside the motor will result in extremely rapid brush wear.

Location

The motor should be installed in an area that is protected from direct sunlight, corrosives, harmful gases or liquids, dust, metallic particles, and vibration. Exposure to these can reduce the operating life and degrade performance. Be sure to allow clearance for ventilation and access for cleaning, repair, service and inspections. Ventilation is extremely important. Be sure the area for ventilation is not obstructed. Obstructions will limit the free passage of air. Motors get warm and the heat must be dissipated to prevent damage. These motors are not designed for atmospheric conditions that require explosion proof operation. They must NOT be used in the presence of flammable or combustible vapors or dust. TEFC motors can be used for indoor or outdoor standard service. They cannot be used outdoors where they would be exposed to freezing rain. Standard TEFC motors are not designed for atmospheric conditions requiring explosion-proof operation, such as flammable or combustible vapors or dust.

Caution:

Do not lift the motor and its driven load by the motor lifting hardware. The motor lifting hardware is adequate for lifting only the motor. Disconnect the load (gears, pumps, compressors, or other driven equipment) from the motor shaft before lifting the motor.

Mounting

The motor must be securely installed to a rigid foundation or mounting surface to minimize vibration and maintain alignment between the motor and shaft load. Failure to provide a proper mounting surface may cause vibration, misalignment and bearing damage. Foundation caps and sole plates are designed to act as spacers for the equipment they support. If these devices are used, be sure that they are evenly supported by the foundation or mounting surface. After installation is complete and accurate alignment of the motor and load is accomplished, the base should be grouted to the foundation to maintain this alignment. The standard motor base is designed for horizontal or vertical mounting. Adjustable or sliding rails are designed for horizontal mounting only. Consult your Baldor distributor or authorized Baldor Service Center for further information.

Alignment

Accurate alignment of the motor with the driven equipment is extremely important.

1. Direct Coupling

For direct drive, use flexible couplings if possible. Consult the drive or equipment manufacturer for more information. Mechanical vibration and roughness during operation may indicate poor alignment. Use dial indicators to check alignment. The space between coupling hubs should be maintained as recommended by the coupling manufacturer.

2. End-Play Adjustment

The axial position of the motor frame with respect to its load is also extremely important. The motor bearings are not designed for excessive external axial thrust loads. Improper adjustment will cause failure.

3. Pulley Ratio

The pulley ratio should not exceed 8:1. Consult your Baldor distributor or authorized Baldor Service Center for further information.

Caution:

Do not over tension belts. Excess tension may damage the motor or driven equipment.

4. Belt Drive

Refer to NEMA MG 1 section 14.07 or Baldor application section for the application of pulleys, sheaves, sprockets, and gears. Align sheaves carefully to minimize belt wear and axial bearing loads (see End-Play Adjustment). Belt tension should be sufficient to prevent belt slippage at rated speed and load. However, belt slippage may occur during starting. Do not over-tension belts.

Caution:

Series wound motors must never be allowed to run with no load (broken belt etc.) An unloaded motor may reach destructive high speeds.

Doweling & Bolting

After proper alignment is verified, dowel pins should be inserted through the motor feet into the foundation. This will maintain the correct motor position should motor removal be required. (Baldor motors are designed for doweling.)

1. Drill dowel holes in diagonally opposite motor feet in the locations provided.

2. Drill corresponding holes in the foundation.

3. Ream all holes.

4. Install proper fitting dowels.

5. Mounting bolts must be carefully tightened to prevent changes in alignment. Use a flat washer and lock washer under each nut or bolt head to hold the motor feet secure. Flanged nuts or bolts may be used as an alternative to washers.

WARNING: Guards must be installed for rotating parts such as couplings, pulleys, external fans, and unused shaft extensions, should be permanently guarded to prevent accidental contact by personnel. Accidental contact with body parts or clothing can cause serious or fatal injury.

Guarding

Guards must be installed for rotating parts such as couplings, pulleys, external fans, and unused shaft extensions. This is particularly important where the parts have surface irregularities such as keys, key ways or set screws. Some satisfactory methods of guarding are:

1. Covering the machine and associated rotating parts with structural or decorative parts of the driven equipment.
2. Providing covers for the rotating parts. Covers should be sufficiently rigid to maintain adequate guarding during normal service.

Power Connection

Motor and control wiring, overload protection, disconnects, accessories and grounding should conform to the National Electrical Code and local codes and practices. Ground the motor by attaching a strap from an established ground point to the grounding bolt provided inside the conduit box.

Conduit Box

For ease of making connections, an oversize conduit box is provided. The box can be rotated 360° in 90° increments.

Power

Connect the motor leads as shown on the connection diagram located on the name plate or inside the cover on the conduit box. Be sure the following guidelines are met:

1. DC power is within ±5% of rated voltage (not to exceed 600VDC). (See motor name plate for ratings).

OR

2. DC field power is within ±1% of rated voltage.

Motor Connections

Terminal connections should be made as specified. See the connection diagrams located in Section 4 of this manual. Tables 2-1 and 2-2 show the NEMA standard lead markings and the Accessory Markings.

Table 2-1 NEMA Standard Lead Markings

Lead Markings	Motor
Armature	A1, A2
Field (shunt)	F1, F2, F3, F4, etc.
Field (series)	S1, S2
Thermostat	P1, P2, etc.
Space Heater	H1, H2, H3, H4, etc.
Thermal Protector	P1, P2, P3, P4, etc.
Resistance Temperature Detector (RTD)	R1, R2, R3, R4, etc.
Optional Brush Monitor System	A1Probe, A2Probe

Table 2-2 Accessory Markings

DC Tachometers	+	—	
	XPY	1	2 G
	XC	Red (1)	Black (2) G
	RL		
AC Tachometers 45/90V Output			
	45V	Red	White
	90V	Red	Black
Brake Coil Leads		B1, B2, B3, etc.	
Space Heater (Brake)		H1, H2, H3, H4, etc.	
Brake Interlock Switch		BS1, BS2, BS3, etc.	

Figure 2-1 Encoder Connections

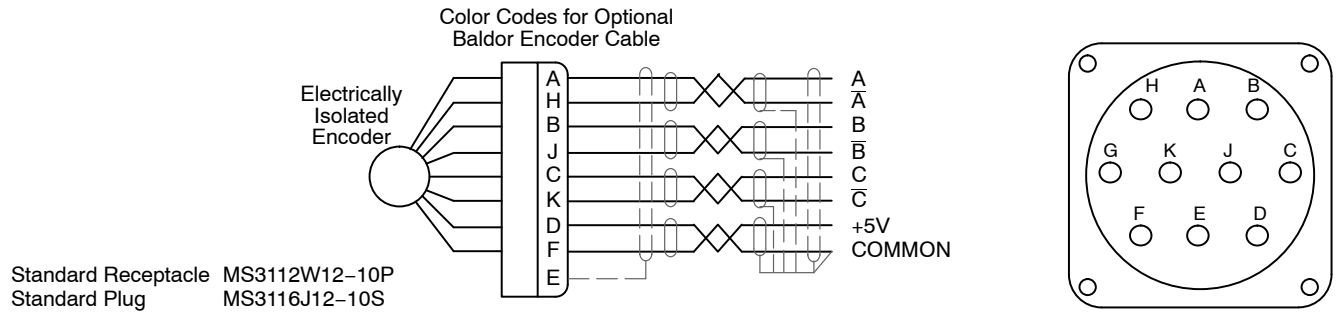

Thermostats The thermostat is a pilot circuit device used in a protective relay circuit. Thermostat ratings are given in Table 2-3.

Table 2-3 Thermostat Ratings

Maximum Current Ratings for Thermostats (Normally Open or Closed Contacts)				
Voltage	125VAC	250VAC	24VDC	Continuous Current All Voltages
Amperage	12A	8A	2A	2A

Blower Ventilation System

Before loading a force-ventilated motor, be sure that the blowers, cooling fans, or central air supply systems are operating properly to supply cooling air to the motor. Air filters should also be in place. If you energize the main fields with the motor at standstill, the blowers or external cooling systems must be left on. This will prevent excessive heat buildup that will decrease the life of the insulation.

When using field economy circuits to reduce the voltage to the main fields during standstill, blowers do not need to be left on.

Blower motors should be checked for correct rotation. Don't rely on feeling airflow from the drive end of the motor. Look at the outline drawing or rotation arrow shown on the blower housing. Refer to Figure 2-2.

Figure 2-2 View from Air Inlet (Motor is on Opposite Side)

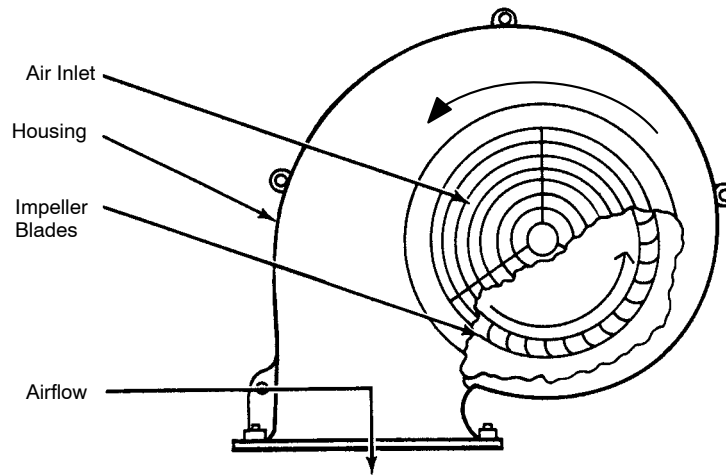

Table 2-4 Electrical Data - Forced Ventilation Blower Units

Size	Motor Frame	HP	RPM	Volts	Phase	Hz	Amps
LM2	180	1/40	3000	230	1	60	0.4
LM3	180	1/8	3450	115/230	1	50/60	2.6/1.3
LM3	210-250	1/8	3450	208-230/460	3	50/60	0.66-0.60/0.30
LM4	280	1/3	3450	208-230/460	3	50/60	1.5-1.4/0.7
LM6	320-400	1	3450	208-230/460	3	50/60	3.1-3.0/1.5
LM8	504-506	3/4	1750	208-230/460	3	50/60	3.4-3.2/1.6
LM9	508-5012	3	3450	208-230/460	3	50/60	8.2-7.6/3.8

Note: Motor mounted blower units. Mount on commutator end (opposite drive end of motor. We supply blowers that are powered by totally enclosed motors (standard). Blowers have a cast aluminum fan housing with washable, wire mesh filters.

Table 2-5 Minimum Blower CFM for DPBV Motors (Drip Proof Blower Ventilated)

Blower Size	Motor Frame Size	Blower CFM	Blower Static Pressure (In H ₂ O)
LM2	180	55	0.50
LM3	180	150	1.45
LM3	210	175	1.45
LM3	250	215	0.78
LM4	280	350	0.88
LM6	320	780	2.80
LM6	360	780	2.80
LM6	400	820	2.50
LM8	504-506	1120	1.58
LM9	508-5012	2000	5.00

Each motor nameplate is stamped with the above data for DPBV (less Blower), DPSV and TEPV enclosures.

Caution: Motors designed for forced ventilation must have cooling air when fields are excited at rated voltage. Installations having the air supply interrupted when the motor is not operating must have field disconnected or field voltage reduced to 67% rated by means of field economizing resistor and relay or motor insulation life will be significantly reduced.

Initial Start-Up

If driven equipment can be damaged by rotating in the wrong direction, uncouple the motor from the load before checking for rotation.

Caution: Series wound motors must never be allowed to run with no load (broken belt etc.) An unloaded motor may reach destructive high speeds.

If the direction of rotation needs to be corrected, disconnect the input power supply and interchange the appropriate leads. Refer to the motor connection diagrams in Section 4 of this manual.

1. The first start-up and running of the motor should be with the motor uncoupled from the load.
2. Check the direction of rotation by momentarily applying power to the motor.
3. With the motor running, make sure it's running smoothly without too much noise or vibration. If either are present, shut down the motor immediately and find the cause of the problem.

Coupled Start-Up

1. After the first successful no load start-up, stop the motor and assemble the coupling.
2. Align the coupling and be sure it is not binding in any way.
3. The first coupled start-up should be without load. Check to see that the driven equipment is not transmitting any vibration back to the motor through the coupling or the base. Vibrations (if any) should be within acceptable levels.
4. Run about 1 hour with driven equipment unloaded.
5. After completing these steps, the motor can now be loaded.
6. Do not exceed the value of armature nameplate amperes under steady continuous loads.

Section 3

Maintenance & Troubleshooting

General Inspection

Inspect the motor at regular intervals, approximately every 500 hours of operation or every 3 months, whichever occurs first. Keep the motor clean and the ventilation openings clear. The following steps should be performed at each inspection:

1. Check that the motor is clean. Check that the interior and exterior of the motor is free of dirt, oil, grease, water, etc. Oily vapor, paper pulp, textile lint, etc. can accumulate and block motor ventilation. If the motor is not properly ventilated, overheating can occur and cause early motor failure.
2. Periodically measure the motor winding resistance to ensure that the integrity of the winding insulation has been maintained. Record the motor winding resistance. Immediately investigate any significant drop in insulation resistance.
3. Check all electrical connectors to be sure that they are tight.
4. Check for too much vibration or looseness. It may be caused by improper alignment, an unbalanced coupling sheave, damaged motor bearings, or loose mounting bolts. Excessive vibration will damage the motor bearings, brushes and commutator.
5. Listen for unusual noises, especially in the area of the bearings. Also, rubbing or rumbling noises could be signs of internal damage. Check for loose parts on the motor such as thru bolts, hold down bolts, bad alignment of hoods, etc. An unbalanced armature or load may also cause noise.

Note: Motors applied with rectified power supplies will often make a humming noise when operating normally. This is even more noticeable at lower operating speeds. If you can hear a growling or erratic hum, the power supply should be checked for proper operation and phase balance. Improper adjustment or functioning of the power supply can cause overheating of the motor and shorten its life.

6. At start-up, check the tightness of the main and commutating pole bolts (external on the frame) as listed in Table 3-1. Loose pole bolts could be a source of unpleasant noise when rectified power runs the motor.

Table 3-1 Torque Specifications for Commutating and Main Pole Bolts

Frame	Bolt Size	Torque (lb-ft)
180AT	3/8 - 16	24 - 30
210AT	3/8 - 16	24 - 30
250AT	3/8 - 16	24 - 30
280AT	1/2 - 13	60 - 75
320AT	1/2 - 13	60 - 75
360AT	3/8 - 16	24 - 30
400AT	3/8 - 16	24 - 30
500AT	1/2 - 13	60 - 75

Lubrication & Bearings

Bearing grease will lose its lubricating ability over time, not suddenly. The lubricating ability of a grease (over time) depends primarily on the type of grease, the size of the bearing, the speed at which the bearing operates and the severity of the operating conditions. Good results can be obtained if the following recommendations are used in your maintenance program.

Type of Grease

A high grade ball or roller bearing grease should be used. Recommended grease for standard service conditions is Polyrex EM (Mobil).

Equivalent and compatible greases include:

Texaco Polystar, Rykon Premium #2, Pennzoil Pen 2 Lube and Chevron SRI-2.

- Maximum operating temperature for standard motors = 110° C.
- Shut-down temperature in case of a malfunction = 115° C.

Lubrication Intervals

Recommended lubrication intervals are shown in Table 3-2. It is important to realize that the recommended intervals of Table 3-2 are based on average use. Refer to additional information contained in Tables 3-3 and 3-4.

Table 3-2 Lubrication Intervals *

NEMA / (IEC) Frame Size	Base Speed - RPM			
	>2500	1750	1150	<800
Up to 210 incl. (132)	5500 Hrs.	12000 Hrs.	18000 Hrs.	22000 Hrs.
Over 210 to 280 incl. (180)	3600 Hrs.	9500 Hrs.	15000 Hrs.	18000 Hrs.
Over 280 to 360 incl. (225)	* 2200 Hrs.	7400 Hrs.	12000 Hrs.	15000 Hrs.
Over 360 to 500 incl. (300)	*2200 Hrs.	3500 Hrs.	7400 Hrs.	10500 Hrs.

* Lubrication intervals are for ball bearings. For roller bearings, divide the listed lubrication interval by 2.

Table 3-3 Service Conditions

Severity of Service	Ambient Temperature Maximum	Atmospheric Contamination	Type of Bearing
Standard	40° C	Clean, Little Corrosion	Deep Groove Ball Bearing
Severe	50° C	Moderate dirt, Corrosion	Ball Thrust, Roller
Extreme	>50° C * or Class H Insulation	Severe dirt, Abrasive dust, Corrosion	All Bearings
Low Temperature	<-30° C **		All Bearings

* Special high temperature grease is recommended (Dow Corning DC44). Note that Dow Corning DC44 grease does not mix with other grease types. Thoroughly clean bearing & cavity before adding grease.

** Special low temperature grease is recommended (Aeroshell 7). Different brushes may also be required. Contact your local Baldor district office or an authorized Baldor service center for technical assistance.

Table 3-4 Lubrication Interval Multiplier

Severity of Service	Multiplier
Standard	1.0
Severe	0.5
Extreme	0.1
Low Temperature	1.0

Table 3-5 Bearings Sizes and Types

Frame Size NEMA (IEC)	Bearing Description (These are the Large bearings (Shaft End) in each frame size)					
	Bearing	OD D mm	Width B mm	Weight of Grease to add oz (Grams) *	Volume of grease to be added	
					in ³	teaspoon
Up to 210 incl. (132)	6307	80	21	0.30 (8.4)	0.6	2.0
Over 210 to 280 incl. (180)	6311	120	29	0.61 (17)	1.2	3.9
Over 280 to 360 incl. (225)	6313	140	33	0.81 (23)	1.5	5.2
Over 360 to 500 incl. (300)	NU319	200	45	2.12 (60)	4.1	13.4

* Weight in grams = .005 DB

Lubrication Procedure

Be sure that the grease you are adding to the motor is compatible with the grease already in the motor. Consult your Baldor distributor or an authorized service center if a grease other than the recommended type is to be used.

Caution:

To avoid damage to motor bearings, grease must be kept free of dirt. For an extremely dirty environment, contact your Baldor distributor or an authorized Baldor Service Center for additional information.

With Grease Outlet Plug

1. Clean all grease fittings.
2. Remove grease outlet plug.
3. If motor is stopped, add the recommended amount of grease.
If motor is to be greased while running, a slightly greater quantity of grease will have to be added.
Add grease slowly until new grease appears at shaft hole in the endplate or purge outlet plug.
4. Re-install grease outlet plug.

Without Grease Outlet Plug

1. Disassemble motor.
2. Add recommended amount of grease to bearing and bearing cavity. (Bearing should be about 1/3 full of grease and outboard bearing cavity should be about 1/2 full of grease.)

Note: Bearing is 1/3 full when only one side of bearing is completely full of grease.

3. Assemble motor.

Sample Lubrication Determination

Assume - NEMA 286T (IEC 180), 1750 RPM motor driving an exhaust fan in an ambient temperature of 43° C and the atmosphere is moderately corrosive.

1. Table 3-2 list 9500 hours for standard conditions.
2. Table 3-3 classifies severity of service as "Severe".
3. Table 3-4 lists a multiplier value of 0.5 for Severe conditions.
4. Table 3-5 shows that 1.2 in³ or 3.9 teaspoon of grease is to be added.

Note: Smaller bearings in size category may require reduced amounts of grease.

Brush Replacement

Do not change brush grades or suppliers without first contacting Baldor for technical assistance. Brush life will vary greatly due to motor load conditions and the operating environment. The brush pigtail leads should be checked for secure connection to the brush support stud. Brushes should be replaced when their pigtails touch the top of the brush holder.

When replacing brushes, proper seating is important!

1. Wrap a strip of coarse grit (60) sandpaper, rough side out, around the commutator and under the brush holder. (Do not use metal oxide based sandpaper or emery cloth that contains electrically conductive materials).
2. Slide the new brush into the holder and snap the spring clip in place.
3. Rotate the armature slowly in the direction of normal motor rotation.
4. Remove the brush and inspect the face. The brush should be seated over 90% of the face area and completely seated from leading to trailing edge.

Brushes should move freely in their holders. If brushes stick, it is usually due to built up dirt and oil. Brushes should be inspected on occasion to see that they are long enough to press firmly against the commutator. Brush springs should have equal tension. Only brushes of the same size, grade and shape as those originally supplied should be used.

All motors have their brushes set on neutral before leaving Baldor's factory. After replacing the brush holder, realign it to the factory neutral mark.

When replacing a turned-down commutator in the motor with a new commutator, the brush holder assembly must be adjusted. Keep 1/16" clearance between the bottom of the brush holder and commutator. The brush holder assembly is designed with a nut/bolt guide assembly for ease in positioning of the brush-box. During periodic inspections, check that electrical connections are tight and properly insulated.

Brush Springs

Brush springs should be inspected for proper tension during brush replacement. If the spring shows a loss in tension, it should be replaced. Routine replacement of brush springs is recommended with every third set of brushes.

Poor Brush Life

Poor brush life may be caused by overloading, brushes operating at higher than their rated speed, or very light electrical loads. These can be corrected by using a brush with greater current-carrying capacity for overloads. Friction-reducing treatments reduce wear on high speed applications. Where light loading is the cause, the answer may be to remove some brushes from the motor (with multiple brushes per pole).

Another is to install brushes with a higher content of graphite that can handle the lower current and still film properly. Poor brush life is generally not related to the "softness" or "hardness" of the brush.

Do not change brush grades or the number of brushes per pole. Doing so may void the warranty and make the motor unsafe to operate. Contact your local Baldor district office or an authorized Baldor service center for technical assistance.

Brush Chatter or Bounce

Brush chatter or bouncing can be caused by vibration from an external source. This may be a bad gearbox coupling or condition, or insecure mounting of the motor. Stronger carbon grades are available that provide more capacity for the brush to resist vibration. It is always best to fix the cause of the problem.

Brush Sparking

Excessive sparking of brushes may be due to electrical causes such as an overload or a very unstable DC power supply. Mechanical causes include a flat spot on the commutator or external vibration. Changing to a better brush grade, or a split-brush design may be required.

Carbon Brushes For Special Operating Conditions

Sometimes, there are problems if motor operation requires a different design or grade of carbon brush than what was installed when the motor was built. These special operating conditions include long periods of operation with loads that are significantly greater or less than rated load capacity. Also, operation in the presence of certain chemicals, or extreme temperature and humidity can degrade brush performance.

Generally, poor brush life or commutator wear can occur if one or more of the above conditions exist. The brush used doesn't match the operating conditions.

Baldor offers optional brush grades for the above conditions and has replacement brushes available to retrofit motors. Contact your local Baldor District Office or an Authorized Baldor Service Center for technical assistance. Do not change brush grades or the number of brushes per pole. Doing so may void the warranty and make the motor unsafe. Contact your local Baldor district office or an authorized Baldor service center for technical assistance.

Authorized Service

Baldor catalog 505 (and the Baldor CD-ROM) lists service shops authorized to service Baldor DC motors. Contact your local Baldor District Office for more information.

Humidity and Brush Wear

This curve represents 2 grains of water per cubic foot of dry air or 4.6 grams per cubic meter of dry air.

Zone of Safe Brush Operation

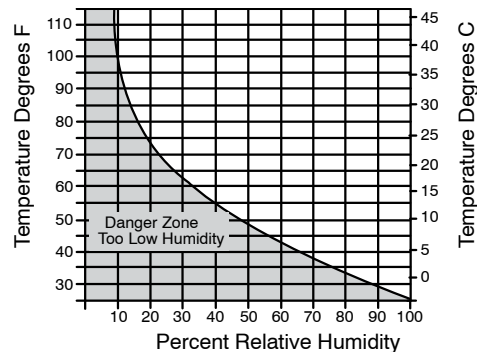

Caution:

Be very careful when repainting a drip proof motor. Do not get any paint on the commutator. Paint on the commutator will show up as black marks in brush tracks. Also, excessive brush sparking or erratic operation can be caused by paint or other material on the commutator.

Commutator

After several hours of operation, the commutator surface under the brush should take on a darker bronze color. This is due to self-generated film caused by normal commutation. This coloration should be even, without blotches or black areas. A shiny copper color or black streaks in the brush tracks are signs of improper commutation or contamination by a foreign material. Contact Baldor for assistance in correcting these problems. If the commutator becomes rough and burned, or becomes black, it should be cleaned of dirt and carbon particles. This can be done by wiping it with a dry, lint-free cloth. Also vacuuming or blowing out the motor with a dry air supply are suitable cleaning methods. Do not use solvents or cleaning solutions on the commutator. To remove spots or contamination that will not wipe off, wrap a strip of coarse (60# grit) sandpaper around the commutator. Then rotate the armature back and forth by hand. Do not use emery cloth as this contains electrically conductive materials.

Another method of commutator resurfacing is to use a commercially available commutator dressing stone. This should only be done by trained and experienced people. This stone should be taped or attached to the end of a stick made of electrically insulated material. The motor should be run at about half speed and the stone applied lightly to the commutator surface. This operation must be done with no load on the motor. The surface of the commutator should be smooth and round. This can be checked while the motor is running at low speed. Press lightly on one brush with an insulated stick. Do not use a lead pencil as this contains electrically conductive graphite. If you feel movement of the brush, it suggests a worn or uneven commutator. The armature must be removed from the motor and the commutator machined by a qualified repair shop.

Rapid Commutator Wear

Light electrical loads and contamination are the usual causes of rapid commutator wear. Light loading may require the removal of some brushes on motors with multiple brushes per pole. Sometimes a low current density brush grade is used. There are also brushes that have a mild polishing action. These prevent certain chemicals, especially chlorine and silicone, from attacking the commutator. Brushes, are available for use in plastic extruder applications where PVC is present. Usually, you do not have to change the design or grade of the brushes on new motors unless special operating conditions exist. Do not change brush grades or the number of brushes per pole. Doing so may void the warranty and make the motor unsafe. Contact your local Baldor district office or an authorized Baldor service center for technical assistance.

Blowers & Filters

Do not use silicone RTV around DC motors as commutator surface damage can occur. Intake filters on blowers and louvers of drip proof motors should be cleaned to remove any dust or foreign matter. Canister type filters should be replaced when dirty. Failure to keep air intakes clear will cause overheating and premature failure of the insulating system.

Guide To Commutator Appearance

(This chart courtesy of Helwig Carbon Products, Inc., Milwaukee, WI)

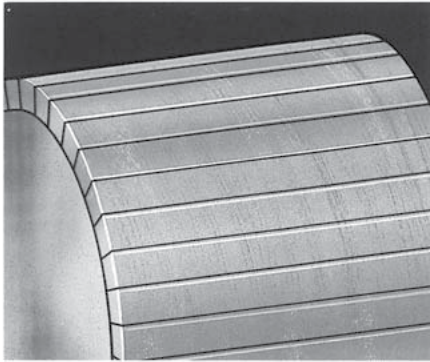

Light Film: Indicates good brush performance. Light load, low humidity, brush grades with low filming rates, or film reducing contamination can cause lighter color.

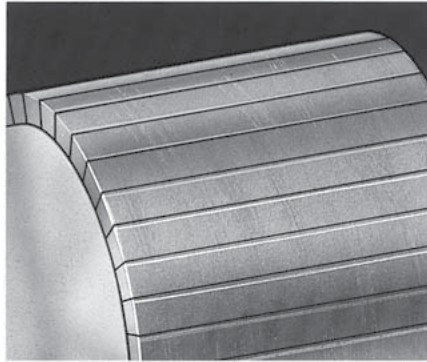

Medium Film: Is the ideal commutator condition for maximum brush and commutator life.

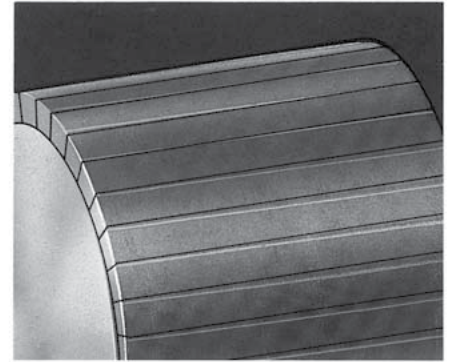

Heavy Film: Results from high load, high humidity or heavy filming rate grades. Colors not in the brown tones indicate contamination resulting in high friction and high resistance.

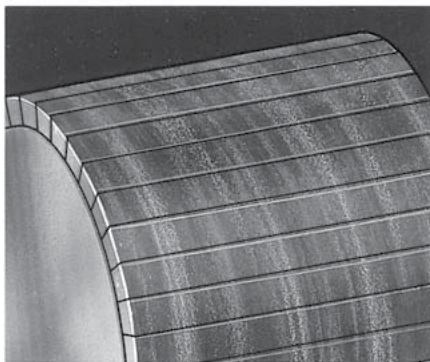

Streaking: Results from metal transfer to the brush face. Light loads and/or light spring pressure are most common causes. Contamination can also be a contributing factor.

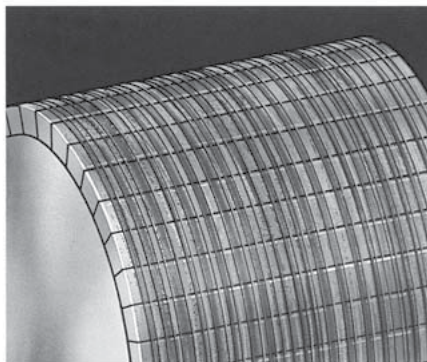

Threading: Is a further development of the streaking condition as the metal transferred becomes work hardened and machines into the commutator surface. With increased loads and increased spring pressure this condition can be avoided.

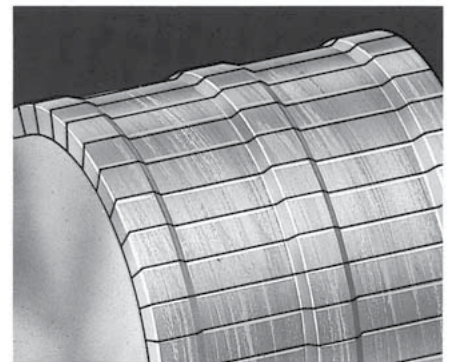

Grooving: May result from an overly abrasive brush grade. The more common cause is poor electrical contact resulting in arcing and the electrical machining of the commutator surface. Increased spring pressure reduces this electrical wear.

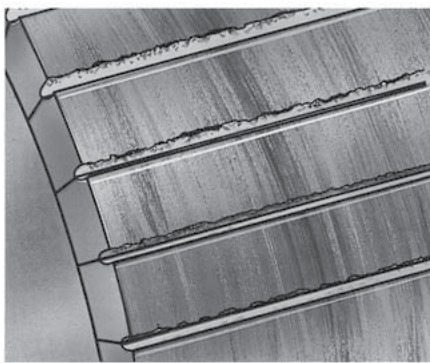

Copper Drag: Develops as the commutator surface becomes overheated and softened. Vibration or an abrasive grade causes the copper to be pulled across the slots. Increased spring pressure will reduce commutator temperature.

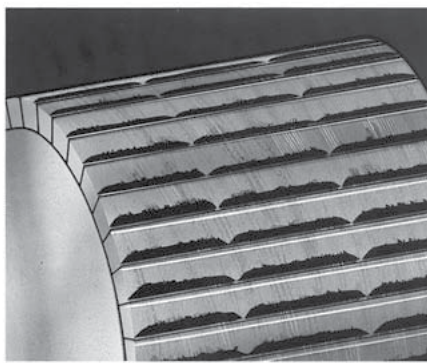

Bar Edge Burning: Results from poor commutation. Check that brush grade has adequate voltage drop, that the brushes are properly set on neutral and that the interpole strength is correct.

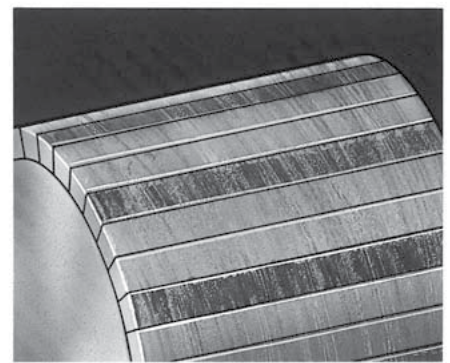

Slot Bar Marking: Results from a fault in the armature windings. The pattern relates to the number of conductors per slot.

Troubleshooting

Armature Overheating

Excessive overloads will cause a noticeable odor of overheated varnish or charred insulation. The commutator may eventually become blackened and pitted and the brushes burned. This overheating may be general and uniform. To cure, remove the overload and rewind or replace armature if damaged beyond use.

An open-circuited armature coil will cause flashing at the commutator. Two adjacent bars will show severe burning and a resulting overheated armature. Short-circuited coils or commutator bars may cause local heating that could destroy the insulation at that spot. This may result in the burning of the armature coils, banding or commutator bars.

Grounds in the armature circuit may be found by measuring the motor winding resistance. If the armature is grounded, less than 1 meg ohm is measured. These tests should be done by experienced and qualified personnel.

Field Coil Overheating

The blowers or external cooling systems should be left in operation if the main field windings remain fully energized with the motor at standstill. Failure to do so may cause too much heat build-up which could cause reduced insulation life.

When using field economy circuits to reduce voltage to the main fields during standstill, blowers do not need to be operating. The most common failure with overheated field coils is a short in one or more of the shunt coils. Shorted coils show less than half the line voltage for two pole motors. This is with the fields connected for high voltage (in series). Shorted four pole motor coils will read less than 1/4 of the line voltage with the coils connected for high voltage (in series).

A grounded coil may cause overheating. This defect may be tested as shown by the ground test for an armature. With brushes lifted, measure the motor winding resistance. If the armature is grounded, less than 1 meg ohm is measured.

An open field coil on a motor will cause the armature to have no torque. The motor may run at a very high speed at no load. The commutator may be flashing. To locate an open coil, apply line voltage to the shunt coils (brushes lifted). A voltmeter will show no reading across a good coil. It will show about the line voltage across the open coil.

These tests should be done by experienced and qualified personnel. If you find any of the above defects, don't run the motor. First contact your local Baldor District Office or an Authorized Baldor Service Center for repairs.

Excessive Load

Excessive load may be found by checking the DC armature ampere input and comparing it with the rating on the nameplate. An excessive load may prevent the motor from starting or accelerating to full load speed. It could finally result in premature failure of the motor or control. Be sure to use an averaging type ammeter if the motor's power is coming from a rectifier or SCR control.

Jogging and Repeated Starts

Repeated starts or jogs of motors may reduce the life of the brushes and winding insulation. The heat produced by excessive starting may be more than what can be dissipated by the motor under a constant full load conditions. If you must frequently start or jog a motor, you should check the application with the local Baldor District Office.

Heating

Duty cycle and maximum ambient temperature are shown on the nameplate of the motor. If there is any question about safe operation, contact the local Baldor District Office.

Motor overheating may be caused by improper ventilation, excessive ambient temperature, dirty conditions or an inoperable blower or dirty filter. Electrical causes may be due to excess current caused by an overload or over-voltage to the fields.

Thermostat

Most stock Baldor DC motors 180 frame and above have a standard temperature-sensing thermostat mounted to their interpole winding. This normally closed thermostat opens when the temperature limit is exceeded. Another option available is a normally open thermostat that closes with temperature.

On blower cooled or separately ventilated motors, the protection capabilities of the thermostats are greatly reduced at low speeds. This is because the interpoles have the same amount of heat transfer regardless of speed. Armature heat transfer is less at low speed. There is less internal air turbulence at low speeds causing higher temperatures at the armature.

The thermal time constant for interpoles can be as much as five times longer than the armature's time constant. Because of this, the thermostat cannot be relied upon to protect the armature during extreme overloads lasting a short time.

The ripple of the rectified power supply and manufacturing tolerances of mounting the device affect the thermostat's accuracy.

For thermostat contact ratings, refer to Thermostats in Section 2 of this manual.

Table 3-6 Troubleshooting Chart

Symptom	Possible Causes	Possible Solutions
Motor will not start	Usually caused by line trouble, such as, single phasing at the starter.	Check source of power. Check overloads, fuses, controls, etc.
Excessive humming	High Voltage.	Check input line connections.
	Loose pole pieces.	Torque the bolts as specified in Table 3-1.
Motor Over Heating	Overload. Compare actual amps (measured) with nameplate rating.	Locate and remove source of excessive friction in motor or load. Reduce load or replace with motor of greater capacity.
	Improper ventilation.	Check external cooling blower to be sure air is moving properly across cooling fins. Check blower for proper direction of rotation. Check motor brush covers to ensure they are solid on the commutator end and that they are not louvered. Check filter for dirt, clean or replace. Excessive dirt build-up on motor. Clean motor.
	Armature rubbing on stator.	Check air gap clearance and bearings.
		Tighten Thru Bolts that hold the endplates to frame. Torque the pole bolts as specified in Table 3-1.
	Field over voltage.	Check input voltage.
	Full voltage on field with motor stopped.	Reduce field voltage to 60% with field economy circuit in the control.
	Grounded winding.	Perform dielectric test and repair as required.
	Improper connections.	Inspect all electrical connections for proper termination, clearance, mechanical strength and electrical continuity. Refer to connection diagram.
Bearing Over Heating	Misalignment.	Check and align motor and driven equipment.
	Excessive belt tension.	Reduce belt tension to proper point for load.
	Excessive end thrust.	Reduce the end thrust from driven machine.
	Excessive grease in bearing.	Remove grease until cavity is approximately 3/4 filled.
	Insufficient grease in bearing.	Add grease until cavity is approximately 3/4 filled.
	Dirt in bearing.	Clean bearing cavity and bearing. Repack with correct grease until cavity is approximately 3/4 filled.
Vibration	Misalignment.	Check and align motor and driven equipment.
	Rubbing between rotating parts and stationary parts.	Isolate and eliminate cause of rubbing.
	Armature out of balance.	Have armature balance checked and repaired at your Baldor Service Center.
	Resonance.	Tune system or contact your Baldor Service Center for assistance.
Noise	Foreign material in air gap or ventilation openings.	Remove armature and foreign material. Reinstall armature. Check insulation integrity. Clean ventilation openings.
Growling or whining	Bad bearing.	Replace bearing. Clean all grease from cavity and new bearing. Repack with correct grease until cavity is approximately 3/4 filled.

Reflash Instructions

Instructions to reflash the residual magnetism for Lifting Magnet Generators only. These generators are self-exciting. If voltage will not build up, it is possible the residual magnetism is insufficient to initiate excitation. This procedure is to restore sufficient residual magnetism to self excite.

Note: Loss of residual magnetism can be caused by misconnection (reversing the connections) of F1 and F4.

1. Disconnect F1 and F4. All other leads may remain connected.
2. Connect 24 to 40VDC power source positive lead to F1 and negative to F4.
DC source may be batteries, a DC welder (not AC) or rectified AC.
3. Drive generator at rated RPM.
4. Measure the voltage across A1 and A2. Voltage should be 150 to 200% of F1 to F4 voltage. When A1 to A2 voltage level reaches this level (approximately 30 seconds) carefully remove the source leads, an arc may be present during disconnect.
5. Stop the generator.
6. Reconnect F1 and F4 as shown in the DC Generator Connection Diagram. Rotation is viewed from opposite drive end (commutator end) A1 is positive for CCW rotation. A2 is positive for CW rotation. S1 is always negative.

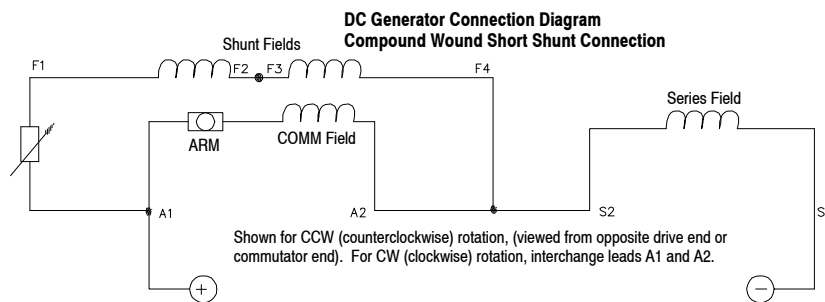

-
- Accessories** The following list shows some accessories available through Baldor's Mod Express or available on custom manufactured motors. Contact your Baldor supplier for information on each additional accessory or those listed below.
- Bearing RTD**
RTD (Resistance Temperature Detector) devices are used to measure or monitor the temperature of the motor bearing during operation.
- Bearing Thermocouples**
Used to measure or monitor bearing temperatures.
- Bearing Thermostat**
Temperature device that activates when bearing temperatures are excessive. Used with an external circuit to warn of excessive bearing temperature or to shut down a motor.
- Blowers with Filters**
Available to increase the constant torque speed range of DPFM motors. This increases the continuous operating torque range at low speeds.
- Brush Wear Indicator**
Provides a warning when the brushes have worn down to the level where they need to be replaced (before damage to the commutator).
- Condensation Drains & Breathers**
Stainless steel drains and separate breathers are available.
- Conduit Boxes**
Optional conduit boxes are available in various sizes to accommodate accessory devices.
- Cord & Plug Assembly**
Adds a line cord and plug for portable applications.
- Drip Covers**
Designed for use when motor is mounted in a vertical position. Contact your Baldor distributor to confirm that the motor is designed for vertical mounting.
- Fan Cover & Lint Screen**
To prevent build-up of debris on the cooling fan.
- Nameplate**
Additional stainless steel nameplates are available.
- Roller Bearings**
Recommended for belt drive applications with a speed of 1800 RPM or less.
- Rotation Arrow Labels**
Rotation arrows are supplied on motors designed to operate in one direction only. Additional rotation arrows are available.
- Slide Bases**
Allows easy belt adjustment while maintaining correct pulley and belt alignment.
- Space Heater**
Added to prevent condensation of moisture within the motor enclosure during periods of shut down or storage.
- Stainless Hardware**
Stainless steel hardware is available. Standard hardware is corrosion resistant zinc plated steel.
- Tachometers**
DC, AC and digital outputs are available. These can be mounted to our motors or shipped separately. Tachs help the SCR control achieve more precise speed regulation than by armature feedback alone.
- Transparent Brush Inspection**
For easy brush inspection and commutation monitoring without disassembly of the motor.
- Winding RTD**
RTD (Resistance Temperature Detector) devices are used to measure or monitor the temperature of the motor winding during operation.
- Winding Thermocouples**
Used to measure or monitor winding temperatures.
- Winding Thermostat**
Temperature device that activates when winding temperatures are excessive. Used with an external circuit to warn of excessive winding temperature or to shut down a motor.

Section 4

Connection Diagrams

Low Voltage connection Shunt Field

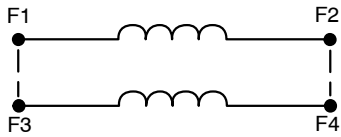

High Voltage connection Shunt Field

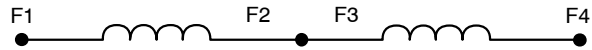

Field Reversing Series Motor

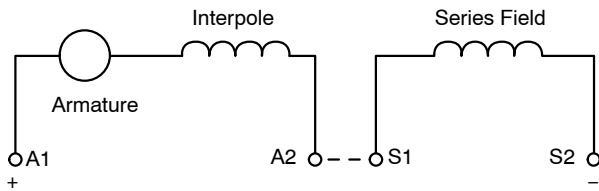

Series Motor CCW Rotation
(Facing Commutator End)

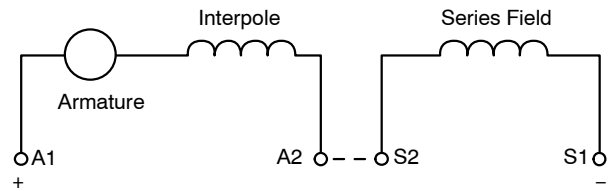

Series Motor CW Rotation
(Facing Commutator End)

Armature Reversing Compound and Stabilized Motors

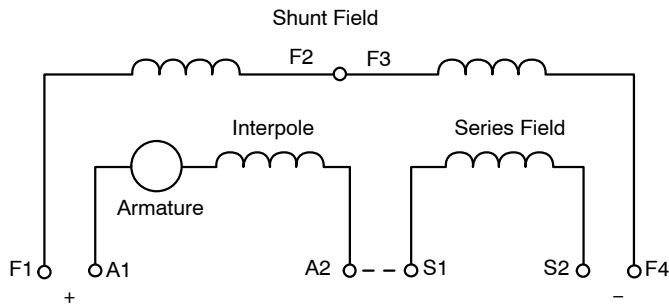

Compound or Stabilized Shunt Motor
CCW Rotation (Facing Commutator End)
High Voltage Field Connection

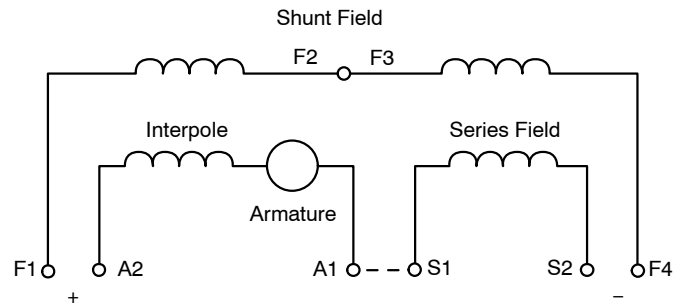

Compound or Stabilized Shunt Motor
CW Rotation (Facing Commutator End)
High Voltage Field Connection

Field Reversing Shunt Motor

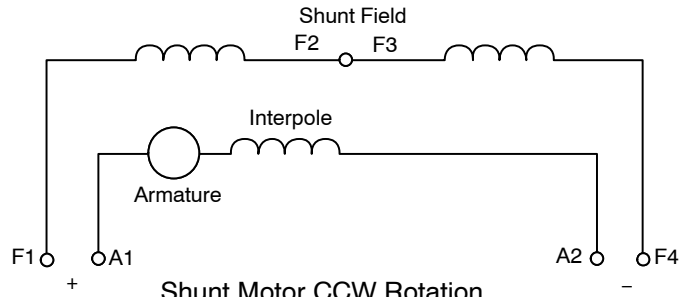

Shunt Motor CCW Rotation
(Facing Commutator End)
High Voltage Field Connection

Field Reversing Shunt Motor

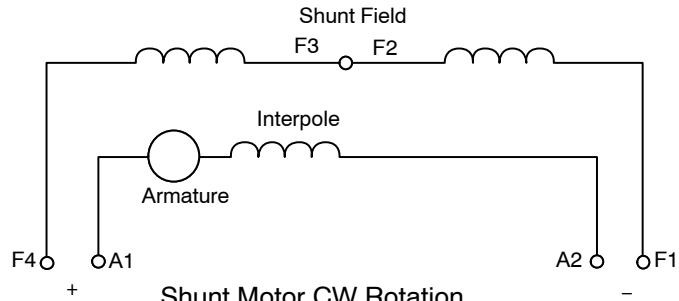

Shunt Motor CW Rotation
(Facing Commutator End)
High Voltage Field Connection

**DC Generator Connection Diagram
Compound Wound Short Shunt Connection**

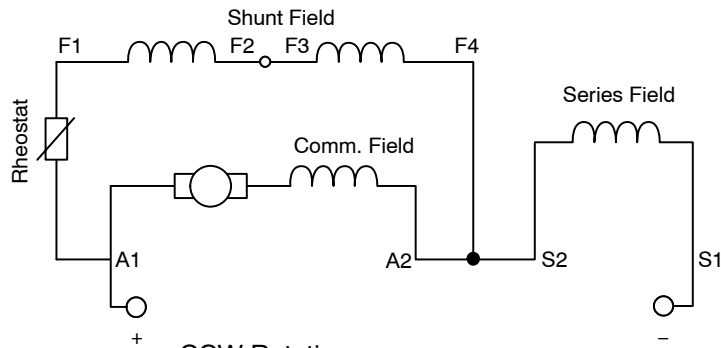

CCW Rotation
(Facing Commutator End)
For CW Rotation, Interchange Leads A1 and A2.

Baldor Sales Offices

UNITED STATES

ARIZONA

PHOENIX

4211 S 43RD PLACE
PHOENIX, AZ 85040
PHONE: 602-470-0407
FAX: 602-470-0464

ARKANSAS

CLARKSVILLE

706 WEST MAIN STREET
CLARKSVILLE, AR 72830
PHONE: 479-754-9108
FAX: 479-754-9205

CALIFORNIA

LOS ANGELES

6480 FLOTILLA STREET
COMMERCE, CA 90040
PHONE: 323-724-6771
FAX: 323-721-5859

HAYWARD

21056 FORBES STREET
HAYWARD, CA 94545
PHONE: 510-785-9900
FAX: 510-785-9910

COLORADO

DENVER

3855 FOREST STREET
DENVER, CO 80207
PHONE: 303-623-0127
FAX: 303-595-3772

CONNECTICUT

WALLINGFORD

65 SOUTH TURNPIKE ROAD
WALLINGFORD, CT 06492
PHONE: 203-269-1354
FAX: 203-269-5485

FLORIDA

TAMPA/PUERTO RICO/ VIRGIN ISLANDS

3906 EAST 11TH AVENUE
TAMPA, FL 33605
PHONE: 813-248-5078
FAX: 813-241-9514

GEORGIA

ATLANTA

62 TECHNOLOGY DRIVE
ALPHARETTA, GA 30005
PHONE: 770-772-7000
FAX: 770-772-7200

ILLINOIS

CHICAGO

340 REMINGTON BLVD.
BOLINGBROOK, IL 60440
PHONE: 630-296-1400
FAX: 630-226-9420

INDIANA

INDIANAPOLIS

5525 W. MINNESOTA STREET
INDIANAPOLIS, IN 46241
PHONE: 317-246-5100
FAX: 317-246-5110

IOWA

DES MOINES

1943 HULL AVENUE
DES MOINES, IA 50313
PHONE: 515-263-6929
FAX: 515-263-6515

MARYLAND

BALTIMORE

7071A DORSEY RUN RD
ELKRIDGE, MD 21075
PHONE: 410-579-2135
FAX: 410-579-2677

MASSACHUSETTS

BOSTON

6 PULLMAN STREET
WORCESTER, MA 01606
PHONE: 508-854-0708
FAX: 508-854-0291

MICHIGAN

DETROIT

5993 PROGRESS DRIVE
STERLING HEIGHTS, MI 48312
PHONE: 586-978-9800
FAX: 586-978-9969

MINNESOTA

MINNEAPOLIS

13098 GEORGE WEBER DR, SUITE 400
ROGERS, MN 55374
PHONE: 763-428-3633
FAX: 763-428-4551

MISSOURI

ST LOUIS

13678 LAKEFRONT DRIVE
EARTH CITY, MO 63045
PHONE: 314-373-3032
FAX: 314-373-3038

KANSAS CITY

1501 BEDFORD AVENUE
NORTH KANSAS CITY, MO 64116
PHONE: 816-587-0272
FAX: 816-587-3735

NEW YORK

AUBURN

ONE ELLIS DRIVE
AUBURN, NY 13021
PHONE: 315-255-3403
FAX: 315-253-9923

NORTH CAROLINA

GREENSBORO

1220 ROTHERWOOD ROAD
GREENSBORO, NC 27406
PHONE: 336-272-6104
FAX: 336-273-6628

OHIO

CINCINNATI

2929 CRESCENTVILLE ROAD
WEST CHESTER, OH 45069
PHONE: 513-771-2600
FAX: 513-772-2219

OHIO (Continued)

CLEVELAND

8929 FREEWAY DRIVE
MACEDONIA, OH 44056
PHONE: 330-468-4777
FAX: 330-468-4778

OKLAHOMA

TULSA

5555 E. 71ST ST., SUITE 9100
TULSA, OK 74136
PHONE: 918-366-9320
FAX: 918-366-9338

OREGON

PORTLAND

12651 SE CAPPS ROAD
CLACKAMAS, OR 97015
PHONE: 503-691-9010
FAX: 503-691-9012

PENNSYLVANIA

PHILADELPHIA

1035 THOMAS BUSCH
MEMORIAL HIGHWAY
PENNSAUKEN, NJ 08110
PHONE: 856-661-1442
FAX: 856-663-6363

PITTSBURGH

159 PROMINENCE DRIVE
NEW KENSINGTON, PA 15068
PHONE: 724-889-0092
FAX: 724-889-0094

TENNESSEE

MEMPHIS

4000 WINCHESTER ROAD
MEMPHIS, TN 38118
PHONE: 901-365-2020
FAX: 901-365-3914

TEXAS

DALLAS

2920 114TH STREET SUITE 100
GRAND PRAIRIE, TX 75050
PHONE: 214-634-7271
FAX: 214-634-8874

HOUSTON

10355 W. LITTLE YORK ROAD
SUITE 300
HOUSTON, TX 77041
PHONE: 281-977-6500
FAX: 281-977-6510

UTAH

SALT LAKE CITY

2230 SOUTH MAIN STREET
SALT LAKE CITY, UT 84115
PHONE: 801-832-0127
FAX: 801-832-8911

WISCONSIN

MILWAUKEE

1960 SOUTH CALHOUN ROAD
NEW BERLIN, WI 53151
PHONE: 262-784-5940
FAX: 262-784-1215

INTERNATIONAL SALES

FORT SMITH, AR

P.O. BOX 2400
FORT SMITH, AR 72902
PHONE: 479-646-4711
FAX: 479-648-5895

CANADA

EDMONTON, ALBERTA

4053-92 STREET
EDMONTON, ALBERTA T6E 6R8
PHONE: 780-434-4900
FAX: 780-438-2600

TORONTO

OAKVILLE, ONTARIO

2910 BRIGHTON ROAD
OAKVILLE, ONTARIO, CANADA L6H 5S3
PHONE: 905-829-3301
FAX: 905-829-3302

MONTREAL, QUEBEC

5155 J-ARMAND BOMBARDIER
SAINT-HUBERT, QUÉBEC
CANADA J3Z 1G4
PHONE: 514-933-2711
FAX: 514-933-8639

VANCOUVER,

BRITISH COLUMBIA

1538 KEBET WAY
PORT COQUITLAM,
BRITISH COLUMBIA V3C 5M5
PHONE 604-421-2822
FAX: 604-421-3113

WINNIPEG, MANITOBA

54 PRINCESS STREET
WINNIPEG, MANITOBA R3B 1K2
PHONE: 204-942-5205
FAX: 204-956-4251

MEXICO

LEON, GUANAJUATO

KM. 2.0 BLVD. AEROPUERTO
LEON, GUANAJUATO, CP37545
MEXICO
FAX: +52 477 761 2010



Baldor Electric Company

P.O. Box 2400, Fort Smith, AR 72902-2400 U.S.A., Ph: (1) 479.646.4711, Fax (1) 479.648.5792, International Fax (1) 479.648.5895
www.baldor.com