



Sizes 2-1/2" - 4"

TB Series True Union Ball Valves

2-1/2" TO 6" PVC AND CPVC

KEY FEATURES

- PVC or CPVC
- Full Port Design Through 4"
- Reversible PTFE Seats
- Double O-Ring Stem Seals
- Easily Actuated
- NSF / ANSI 61 Listed
- Actuator-Ready Design

OPTIONS

- Pneumatic and Electric Actuators
- Lockouts Available
- Gear Operator
- 2" Square Operating Nuts
- Stem Extensions
- Spring Return Handle

MATERIALS

- PVC Cell Class 12454 per ASTM D1784
- CPVC Cell Class 23447 per ASTM D1784
- FPM and EPDM O-Ring Seals

TECHNICAL INFORMATION

EXPLODED VIEW

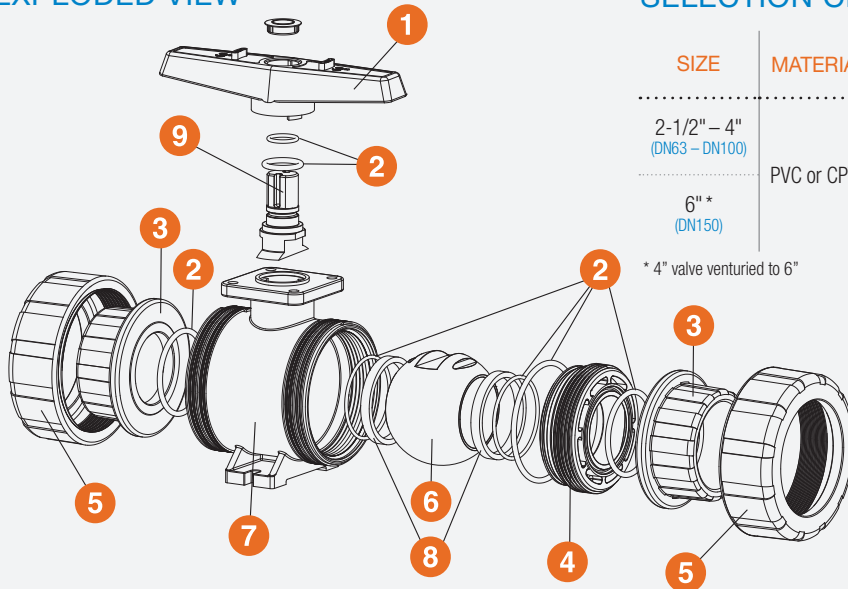

SELECTION CHART

SIZE	MATERIAL	END CONNECTION	SEALS	PRESSURE RATING
2-1/2" - 4" (DN63 - DN100)	PVC or CPVC	Socket, Threaded or Flanged**	FPM or EPDM	235 PSI @ 70°F Non-Shock
6" * (DN150)		Flanged		150 PSI @ 70°F Non-Shock

* 4" valve venturied to 6"

** All flanged valves are rated to 150 PSI @ 70°F Non-Shock

TB Series True Union Ball Valves

2-1/2" TO 6" PVC AND CPVC

TECHNICAL INFORMATION, CONTINUED

PARTS LIST

1. Handle
2. O-Ring Seals
3. End Connector
4. Seal Retainer
5. Union Nut
6. Ball
7. Body
8. PTFE Seat
9. Stem
10. Actuator Mounting Bracket*

* Mounting bracket sold separately

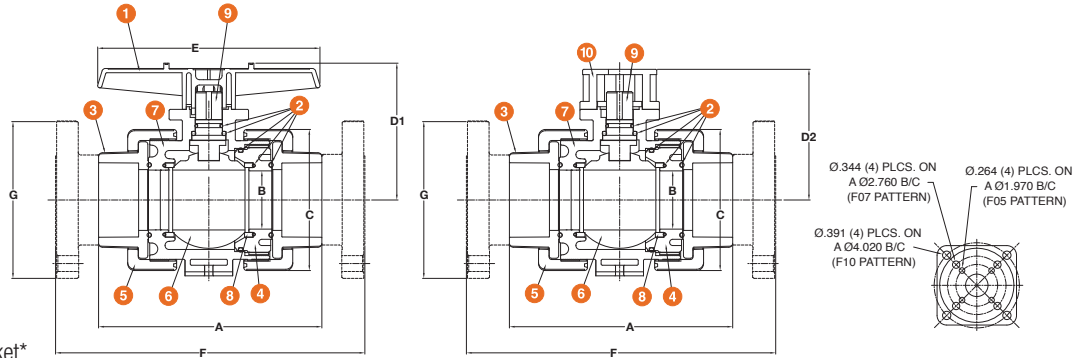

DIMENSIONS – INCHES / MILLIMETERS

SIZE in / DN	A in / mm	B in / mm	C in / mm	D1 in / mm	D2 in / mm	E in / mm	F in / mm	G in / mm	WEIGHT lbs / kg	
									SOC / THD	FLANGED
2-1/2 / 63	10.68 / 271	2.75 / 70	6.66 / 169	6.46 / 164	6.17 / 157	10.50 / 267	14.65 / 372	7.00 / 178	11.30 / 5.13	15.30 / 6.94
3 / 80*	10.56 / 268	2.75 / 70	6.66 / 169	6.46 / 164	6.17 / 157	10.50 / 267	14.60 / 371	7.90 / 200	11.30 / 5.13	15.30 / 6.94
4 / 100*	12.30 / 312	3.81 / 97	8.56 / 217	7.62 / 194	6.64 / 168	10.50 / 267	17.26 / 438	8.96 / 228	18.50 / 8.39	25.70 / 11.66
6 / 150*	N/A	3.81 / 97	8.56 / 217	7.62 / 194	6.64 / 168	10.50 / 267	19.26 / 489	11.00 / 279	N/A	30.75 / 13.95

Dimensions are subject to change without notice – consult factory for installation information

* Metric End Connections Available In: BSP – Straight Thread, BSP TR – Tapered Thread and Metric Socket

Cv VALUES

SIZE in / DN	Cv VALUES GPM	SIZE in / DN	Cv VALUES GPM	PRESSURE LOSS CALCULATION FORMULA
2-1/2 / 63	340.0	4 / 100	600.0	
3 / 80	490.0	6 / 150	550.0	

OPERATING TEMPERATURE / PRESSURE

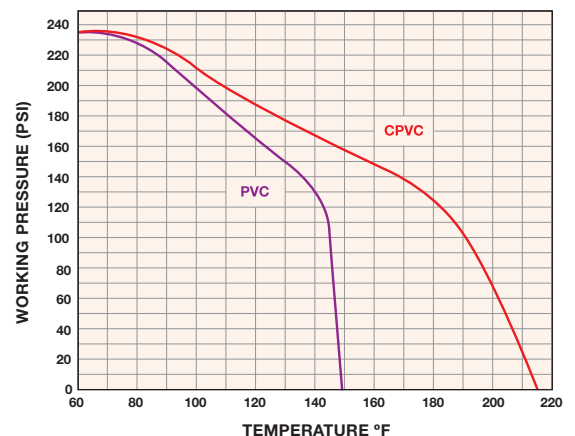

Hayward is a registered trademark of Hayward Industries, Inc. © 2011 Hayward Industries, Inc.

Contact Hayward Flow Control with questions: 1-888-429-4635 • Fax: 1-888-778-8410 • One Hayward Industrial Drive • Clemmons, NC 27012 • USA
Visit us at: www.haywardflowcontrol.com • E-mail: hflow@haywardnet.com